

KMS CRYOGENIC VALVE

DN15 - DN20 - DN25 - DN32 - DN40 (44mm) - DN40 (48mm) - DN50

APPLICATIONS:

KMS cryogenic valves are approved for cryogenic liquefied gases such as oxygen (O₂), nitrogen (N₂), carbon dioxide (CO₂), Argon (Ar), Liquefied Natural Gas (LNG) and Acetylene.

Working temperature is -196 °C / -321 °F (77K) up to +120 °C / +248 °F (393K).

Numeral Sayı	Piece Name Parça Adı	Number Adet	Material Malzeme	Norm Standart
1	Body Gövde	1	1.4301	EN 10028-7
2	Retainer Ball Misket	7	1.4301	EN 10028-7
3	Valve Valf	1	ISO	CUZN39PB3
4	Valve Washer Valf Pulu	1	1.4301	EN 10028-7
5	Valve Sealing Teflon Valf Teflonu	1	PTFE 25 %	PTFE 25%
6	Valve Nut Valf Somunu	1	ISO	CUZN39PB3
7	Valve Seal Retainer Washer Teflon Baskı Pulu	1	ISO	CUZN39PB3
8	Stem Hareket Mili	1	1.4301	EN 10028-7
9	Body Cover Gövde Üst Grubu	1	1.4301	EN 10028-7
10	Body Cover Bolt Gövde Bağlantı Civatası	1	1.4301	EN 10028-7
11	Stem Cashing Üst Grup Kovanı	1	1.4301	EN 10028-7
12	Stem Sealing Male Bushing Erkek Teflon	2	PTFE 25 %	PTFE 25%
13	Stem Sealing Bushing Pressing Ring Teflon Baskı Yüzüğü	1	ISO	CUZN39PB3
14	Stem Cashing Nut Üst Grup Somunu	1	ISO	CIZN39PB3
15	Stem Sealing Female Bushing Dişi Teflon	1	PTFE 25 %	PTFE 25 %
16	Handle Volant	1	ETIAL 171	AISI 10mg
17	Handle Washer Volant Pulu	1	1.4301	EN 10028-7
18	Handle Lock Nut Volant Somunu	1	1.4301	EN 10028-7
19	Gasket Sızdırmazlık Contası	1	CU	C71500

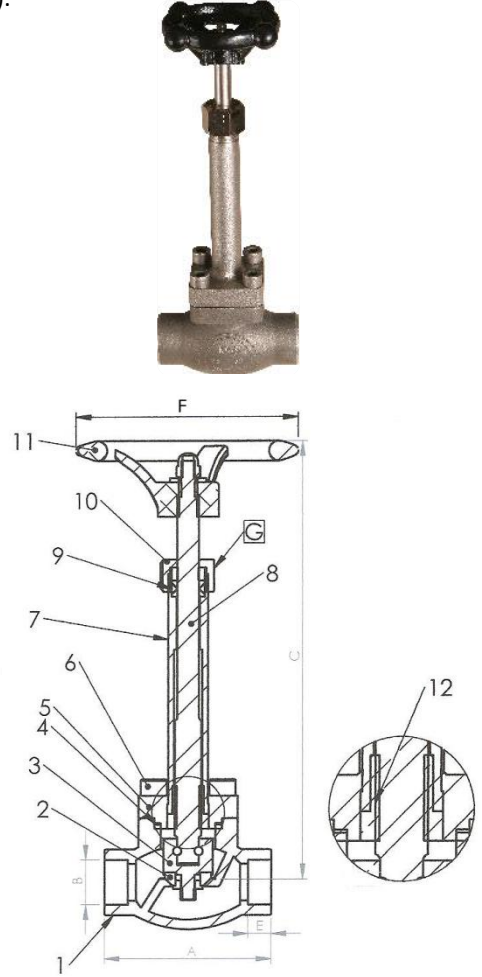

Standard marking according to Pressure Equipment Directive 97/23/EC (PED).

Marking According to Transportable Pressure Equipment Directive 99/36/EC (TPED) will only be carried out by written notice on purchase order.



Standard Design Technical Data								
Nominal Size	DN	15	20	25	32	40	40	50
Dimension Code / Ölçü Kodu	kd	21	27	34	38	44	48	60
Face-to-Face Dimension / Gövde genişliği	A	85	100	115	115	130	130	155
Height / Yükseklik	C	280 - 370 mm						
Outside Pipe Ø / Soket Çapı	B	21,3	27,3	34	38	44	48	60,3
Socket Dept / Soket Derinliği	E	10	14	14	14	14	14	16
Handwheel Ø / Volan Çapı	F	100	100	100	100	125	125	125
Wrench size across flats / Somun	G	30	30	30	30	30	30	30
Kvs - Value	m ³ / h	4,3	6,7	11,5	14	20,6	22,6	37,1
Cv - Value	gal / min	5	7,8	13,4	16,2	26,3	26,3	43,2

Dimensions in mm.